

DMX-A2-DRV

Integrated Advanced Step Motor Driver

Manual

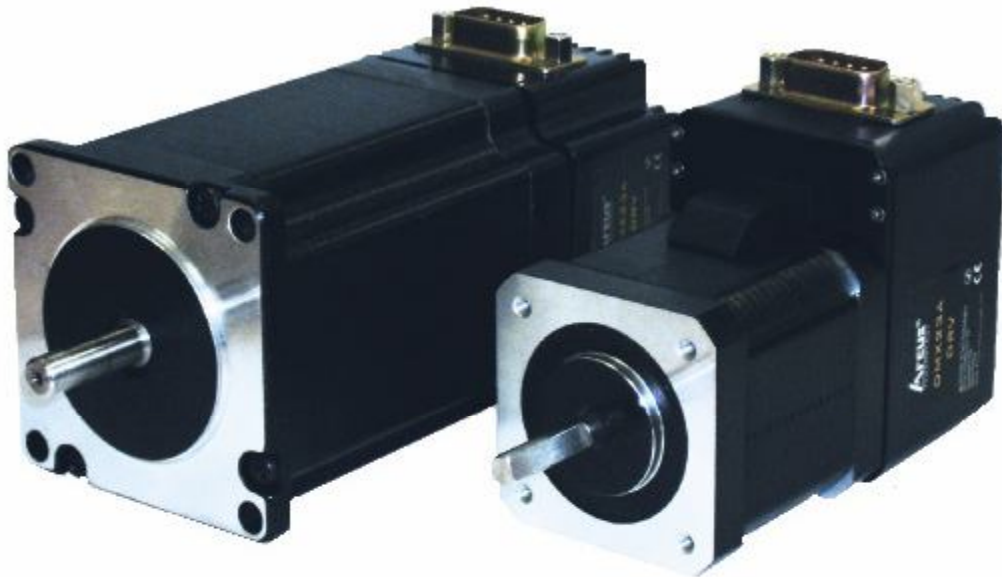

COPYRIGHT © 2008 ARCUS, ALL RIGHTS RESERVED

First edition, May 2008

ARCUS TECHNOLOGY copyrights this document. You may not reproduce or translate into any language in any form and means any part of this publication without the written permission from ARCUS.

ARCUS makes no representations or warranties regarding the content of this document. We reserve the right to revise this document any time without notice and obligation.

Revision History:

- 2.2 – First revision
- 2.3 – Updated pin out spec, updated motor spec, added torque curves, DMX-CFG-USB configuration, added encoder option, added signal current spec, updated alarm output section
- 2.4 – Added dust protection encoder spec

Firmware Compatibility:

V101

Software Compatibility:

NA

Table of Contents

| | |
|---|----|
| 1. Introduction..... | 4 |
| 2. Part Numbering..... | 5 |
| 3. Dimensions | 6 |
| DMX-A2-DRV-17 | 6 |
| DMX-A2-DRV-23 | 7 |
| 4. Motor Specifications | 8 |
| DMX-A2-DRV Standard Motor Specifications | 8 |
| 5. Torque Curves..... | 9 |
| DMX-A2-DRV-17-2/3 | 9 |
| DMX-A2-DRV-23-2/3 | 10 |
| 6. Connectors | 11 |
| DB9 Connector Information | 11 |
| Optional Encoder Pin Out (Open frame) | 12 |
| Optional Encoder Color Code (Dust protected frame) | 13 |
| 7. General Specifications | 14 |
| Power Requirement..... | 14 |
| Operating Temperature | 14 |
| DMX-A2-DRV Interface Circuit..... | 15 |
| Pulse/Dir (CW/CCW) Inputs | 16 |
| Microstep | 17 |
| Current Control | 17 |
| Enable Input..... | 17 |
| Over Temperature Alarm Output..... | 18 |
| 8. Driver Configuration..... | 19 |
| Connecting ACE-SXC/DMX-CFG-USB and DMX-A2-DRV-17/23..... | 21 |
| Configuration Method #1 - Using a controller and Windows PC | 22 |
| USB Device Driver Installation for ACE-SXC/DMX-CFG-USB..... | 22 |
| DMX-A2-DRV Configuration Steps using ACE-SXC and PC..... | 23 |
| DMX-A2-DRV Configuration Steps using DMX-CFG-USB and PC | 26 |
| Configuration Method #2 - Using the Configuration Button..... | 29 |

1. Introduction

DMX-A2-DRV is an integrated step motor and driver with the following features:

- 12-48VDC voltage input
- 100mA to 3.0A peak current setting
- Configurable microstep setting of any value from 2 to 500
- One clock (Pulse/Dir) or Two clock (CW/CCW) support
- 1M maximum pulse rate support
- Opto-isolated differential Pulse/Dir (CW/CCW) inputs
- Opto-isolated driver enable input
- Opto-isolated over-temperature alarm output
- Available in NEMA 17 and 23 motors in various stack sizes.
- Optional 1000 count encoder option (single ended A,B,Z output)

2. Part Numbering

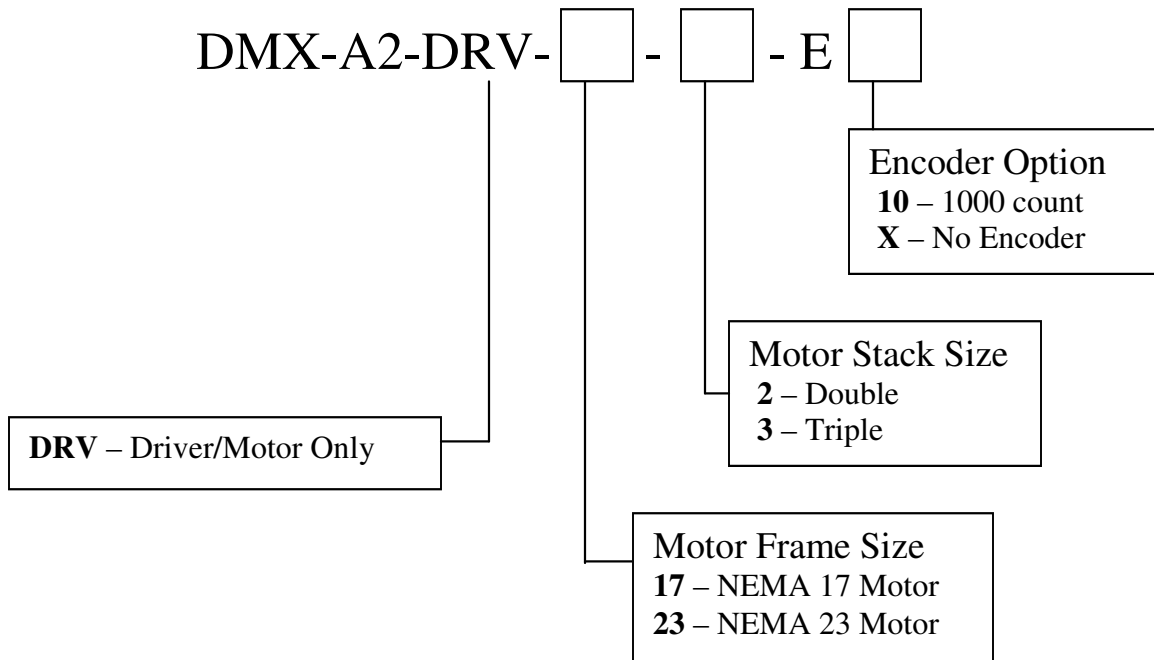

Motor Size – DMX-A2-DRV is available with NEMA 17 or NEMA 23 bi-polar step motors.

Motor Stack - Standard stack size motors available: (2) Double, (3) Triple. Typically, a larger size motor can handle higher torque but is slower and requires higher current.

Encoder Resolution – DMX-A2-DRV is available with optional encoder with quadrature channels (A and B) plus index channel (Z). Encoder resolution is 1000. Other resolutions are available upon special request.

3. Dimensions

DMX-A2-DRV-17

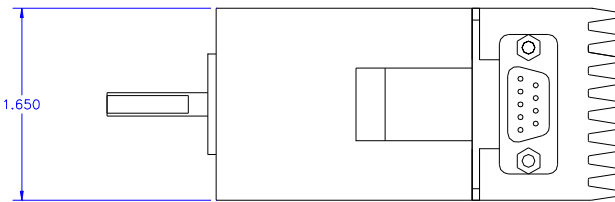
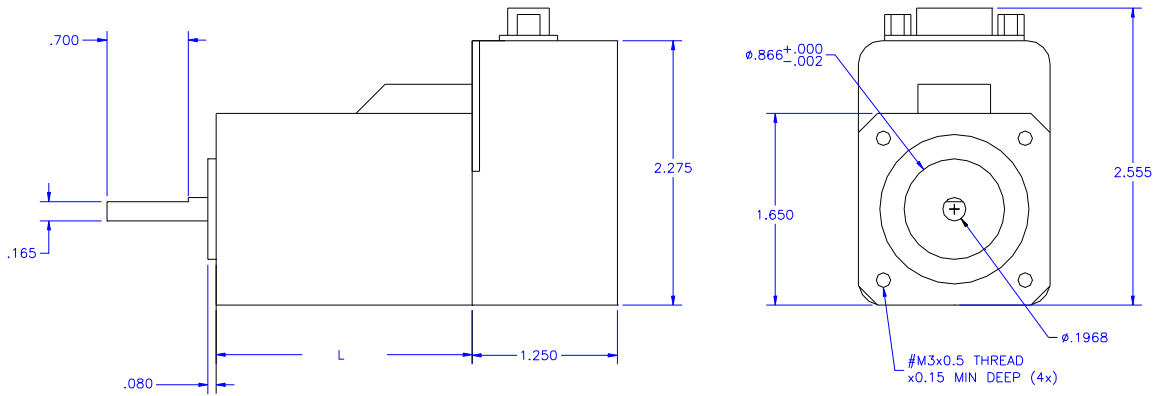

| Model | L (inches) |
|----------------------------|------------|
| DMX-A2-17-2 (Double Stack) | 1.58 |
| DMX-A2-17-3 (Triple Stack) | 1.89 |

DMX-A2-DRV-23

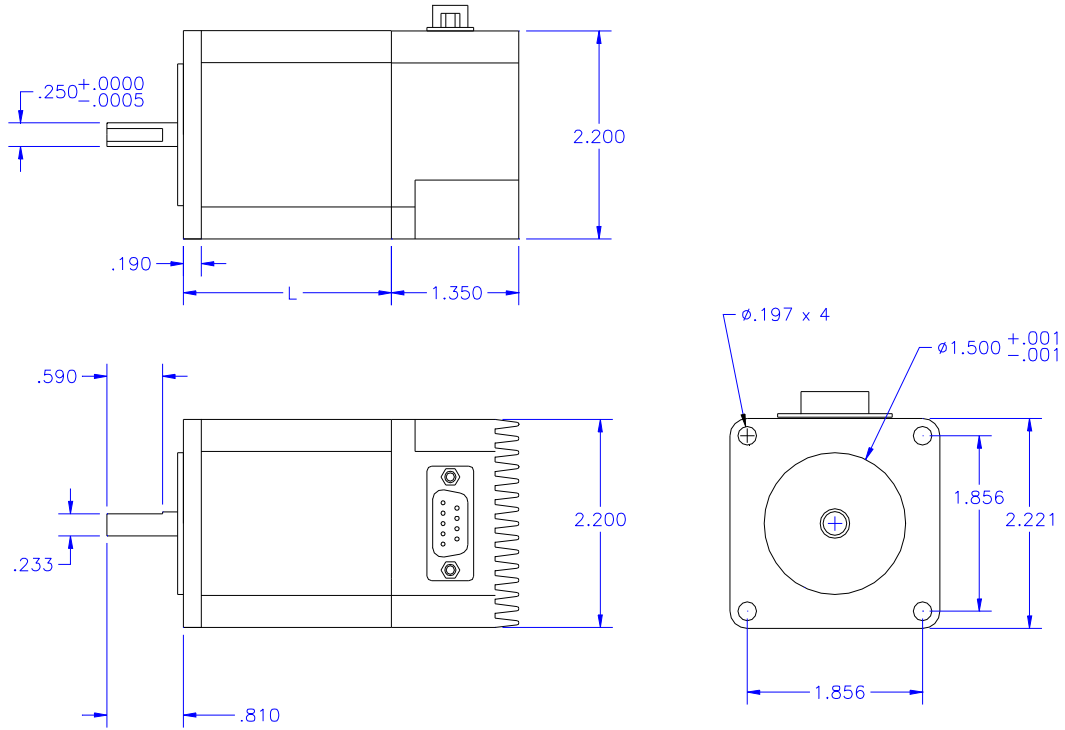

| Model | L (inches) |
|--------------------------------|------------|
| DMX-A2-DRV-23-2 (Double Stack) | 2.2 |
| DMX-A2-DRV-23-3 (Triple Stack) | 3.1 |

4. Motor Specifications

DMX-A2-DRV Standard Motor Specifications

Following chart shows the specifications of standard step motors used for DMX-A2-DRV products. All standard DMX-A2-DRV step motors are 1.8 degree bi-polar step motors.

| NEMA Size | Stack Size | Max Amp / Phase | Holding Torque | Resistance / Phase | Inductance / Phase | Inertia |
|-----------|------------|-----------------|----------------|--------------------|--------------------|-------------------------|
| | Double | 1.7A | 0.44 N-m | 1.5 Ohm | 3.0 mH | 0.28 oz-in ² |
| 17 | Triple | 2.0A | 0.59 N-m | 1.4 Ohm | 2.7 mH | 0.37 oz-in ² |
| | Double | 2.8A | 0.95 N-m | 0.9 Ohm | 2.5 mH | 1.64 oz-in ² |
| 23 | Triple | 2.8A | 1.41 N-m | 1.13 Ohm | 3.6 mH | 2.62 oz-in ² |

5. Torque Curves

DMX-A2-DRV-17-2/3

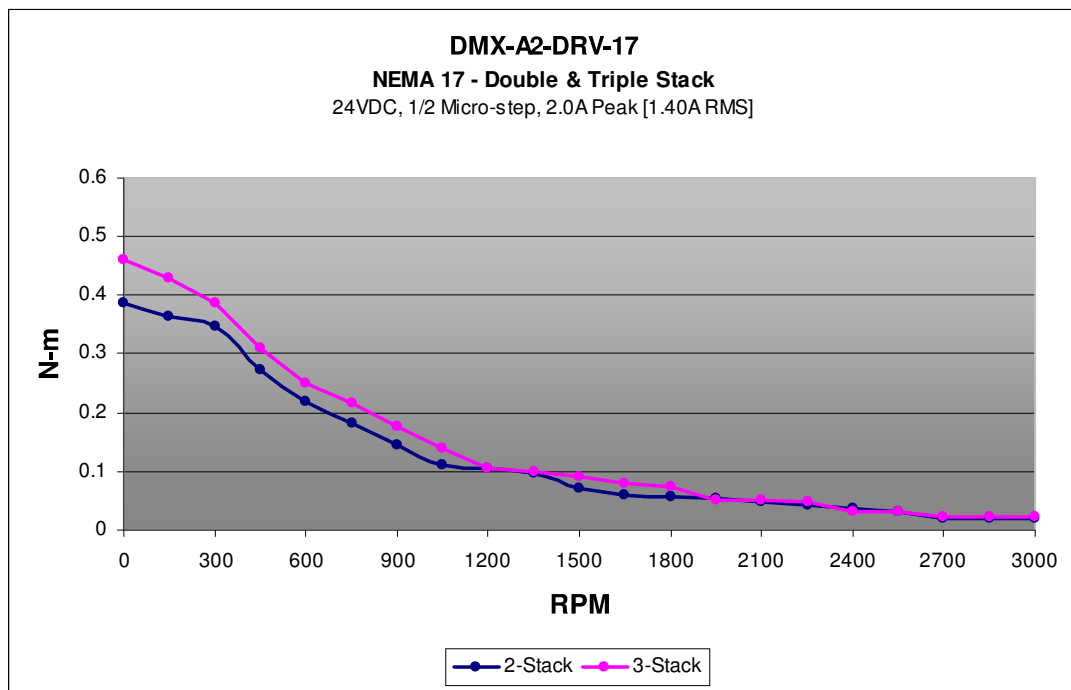
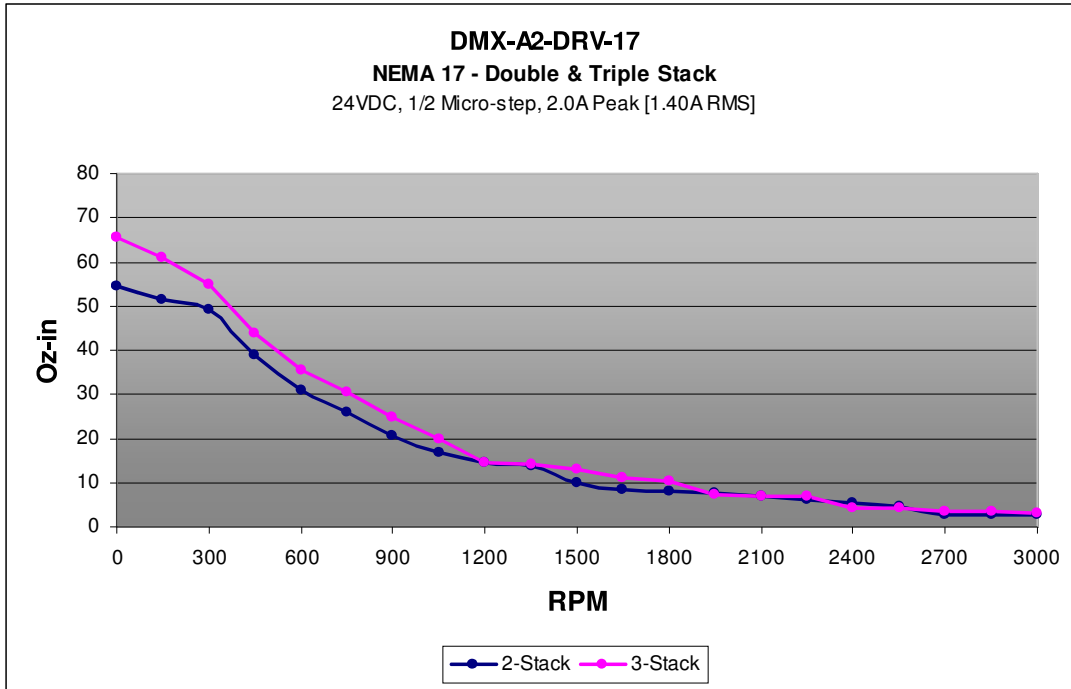

DMX-A2-DRV-23-2/3

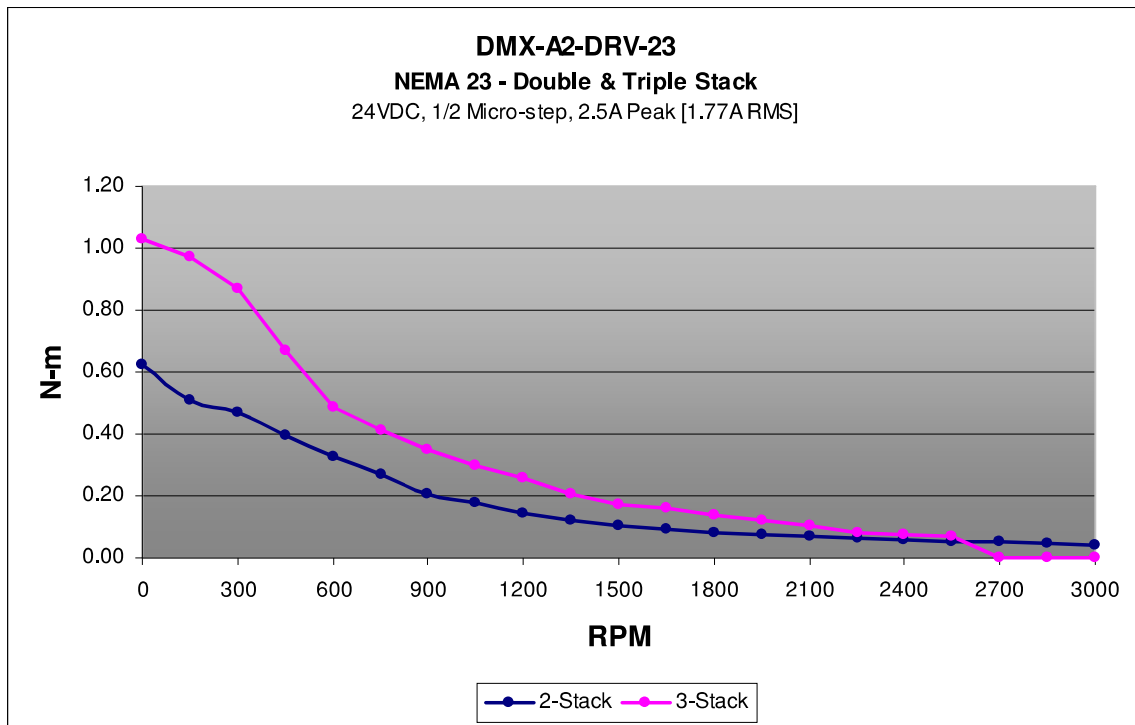
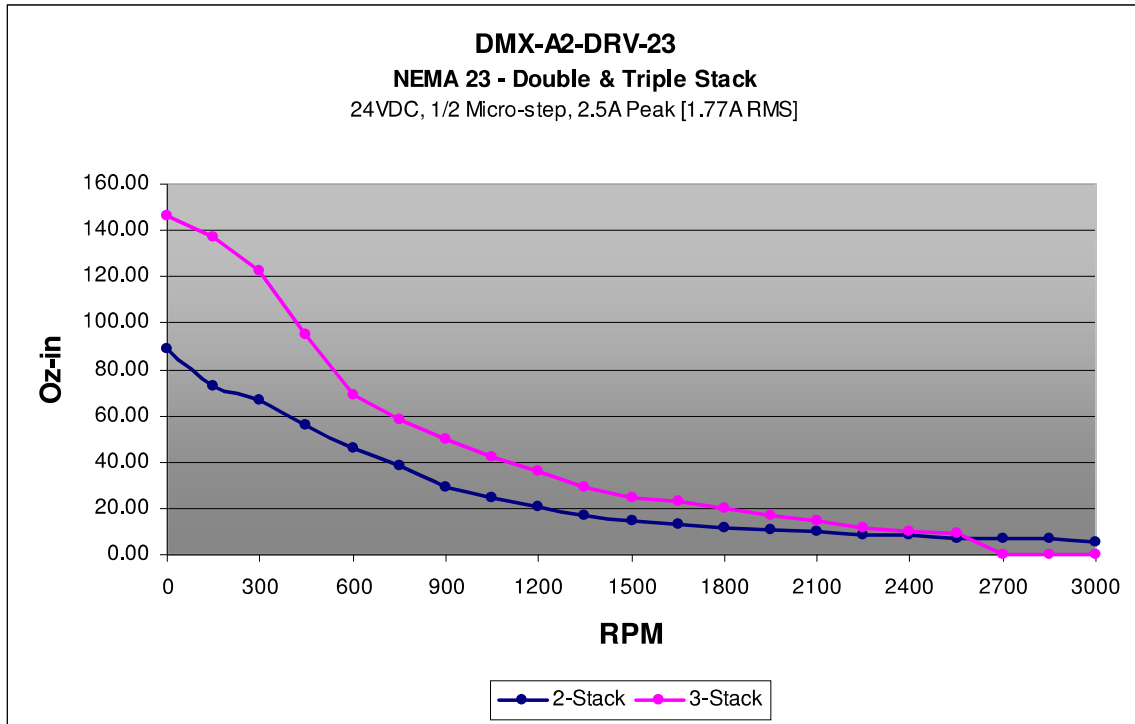

6. Connectors

DMX-A2-DRV uses standard D-SUB 9 connector interface as shown on the picture below.

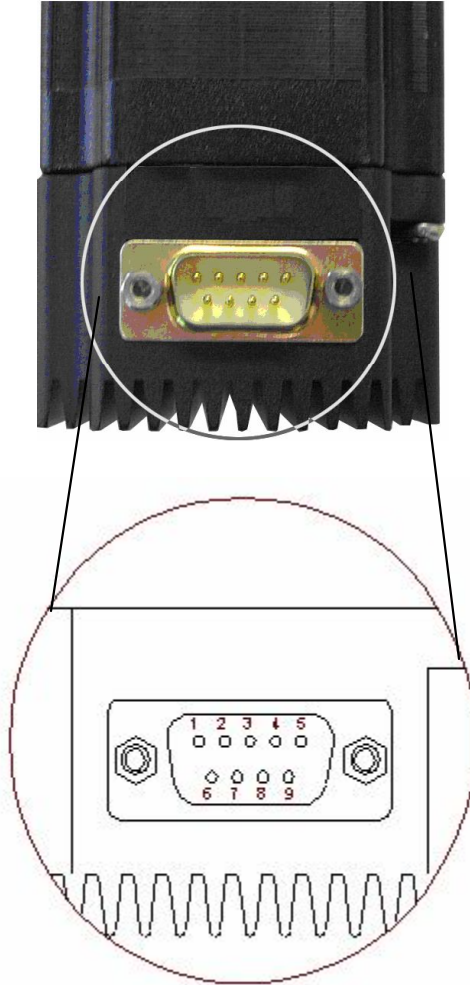

DB9 Connector Information

| Pin # | Name | Description |
|--------------|-------------|---|
| 1 | Power | Power supply input (+12 VDC to +48 VDC) |
| 2 | Pulse | CW (or Pulse) opto-isolated input |
| 3 | Enable | Enable opto-isolated input |
| 4 | Alarm | Over temperature Alarm Output |
| 5 | +5V | 5V output |
| 6 | Ground | Power Ground |
| 7 | Direction | CCW (or Dir) opto-isolated input |
| 8 | NC | No Connection |
| 9 | Opto-supply | Opto-supply input (+5 VDC) |

DMX-A2-DRV allows for an optional single-ended encoder. See encoder pin-out below:

Note: If your DMX-A2-DRV has colored flying lead wires instead of the exposed 5-pin reader, skip to the “Optional Encoder Color Code (Dust protected frame)” section.

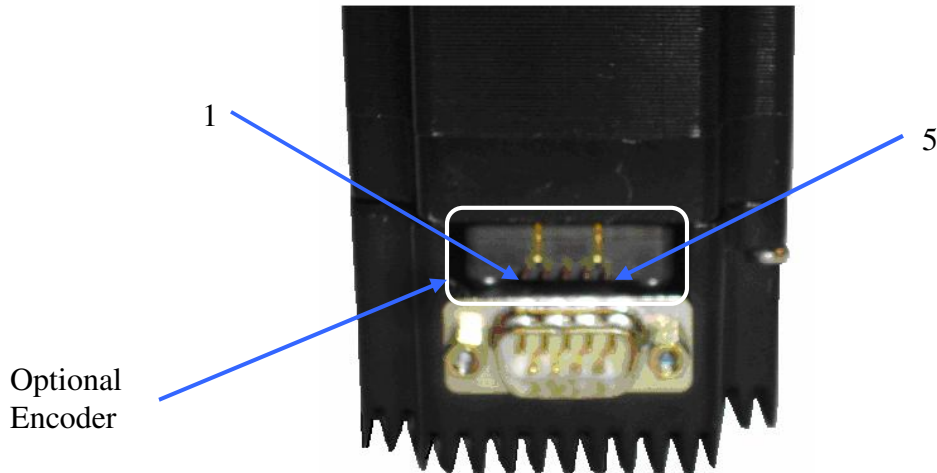

Optional Encoder Pin Out (Open frame)

| Pin # | Name | Description |
|--------------|-------------|---|
| 1 | Ground | Ground |
| 2 | Index | Index Z channel |
| 3 | A | Encoder A channel |
| 4 | +5V | +5V input required to power the encoder |
| 5 | B | Encoder B channel |

Notes:

- Encoder connector is a 0.1” spacing 5-pin connector.
- Standard encoder resolution is 1000 count/rev.
- Integrated encoder is optional.

Newer versions of DMX-A2-DRV protect the encoder from dust with the use of a face plate and grommet. In this case, a color code is used to distinguish between the different encoder signals. See color code below:

Optional Encoder Color Code (Dust protected frame)

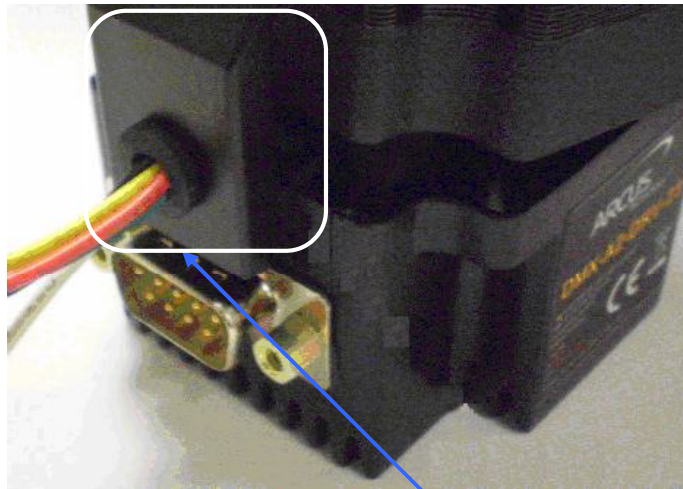

Optional encoder grommet and flying leads

| Color Code | Name | Description |
|-------------------|-------------|---|
| Black | Ground | Ground |
| Yellow | Index | Index Z channel |
| White | A | Encoder A channel |
| Red | +5V | +5V input required to power the encoder |
| Green | B | Encoder B channel |

Notes:

- Standard encoder resolution is 1000 count/rev.
- Integrated encoder is optional.

7. General Specifications

Power Requirement

| | |
|-----------------------------------|-----------------------|
| Regulated Voltage: | +12 to +48 VDC |
| Maximum Current for power supply: | 3 A |

Operating Temperature

Electronic components used in DMX-A2-DRV have maximum ambient operating temperature of **85 degree Celsius**. DMX-A2-DRV electronics are potted with heat-conductive compound to the housing to evenly distribute the heat and reduce any hot spots in the driver. Housing also has integrated fins to better dissipate the heat.

DMX-A2-DRV has internal temperature sensor which protects the driver in case of overheat. At temperature above **75 degrees Celsius**, the driver shuts off automatically to protect the electronics from being damaged. Please refer to temperature sensing section for details.

DMX-A2-DRV should be mounted securely to a metallic bracket that can also act as a heat-sink. During operation, step motor section typically becomes hotter than the driver section. Having the step motor mounted to a heat sink will help dissipate the heat generated by the step motor.

DMX-A2-DRV mounting orientation should be such that the fins are oriented vertically for better convection and heat dissipation.

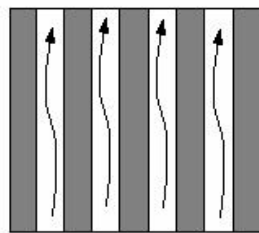

Good Heat Flow

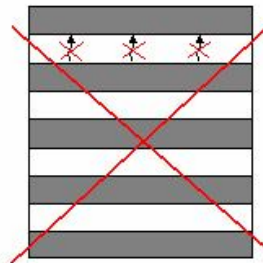

Bad Heat Flow

DMX-A2-DRV Interface Circuit

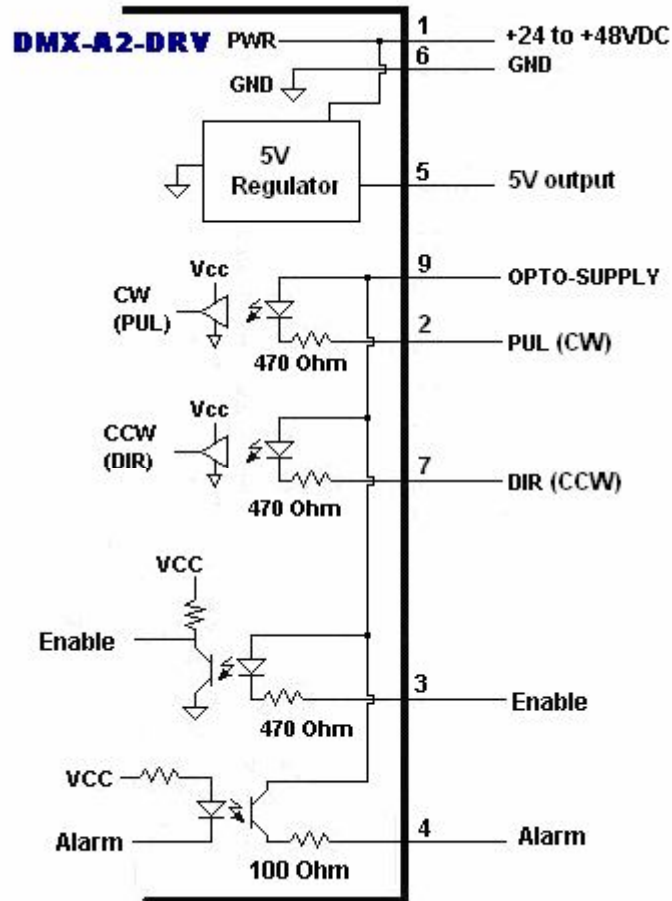

Pulse/Dir (CW/CCW) Inputs

DMX-A2-DRV supports both one-clock (PULSE/DIR) or two-clock (CW/CCW) inputs. One-clock uses PUL signal as pulse train input position control and DIR signal as direction input signal for direction control.

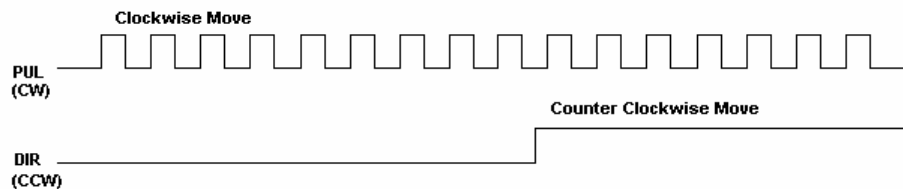

Two-clock uses CW as clockwise pulse input and CCW as counter clockwise pulse input for position control.

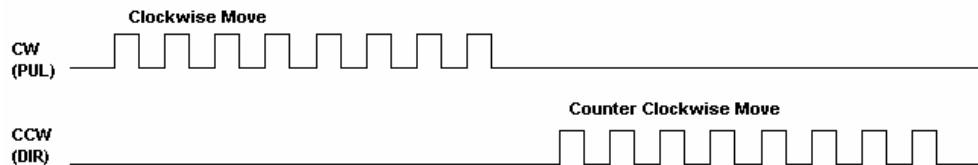

Depending on the direction polarity setting, actual direction of the rotation can be configured for the application.

Pulse/Dir (CW/CCW) inputs are opto-isolated differential inputs with 470 Ohm resistor:

Example of Wiring of Pulse/Dir Inputs

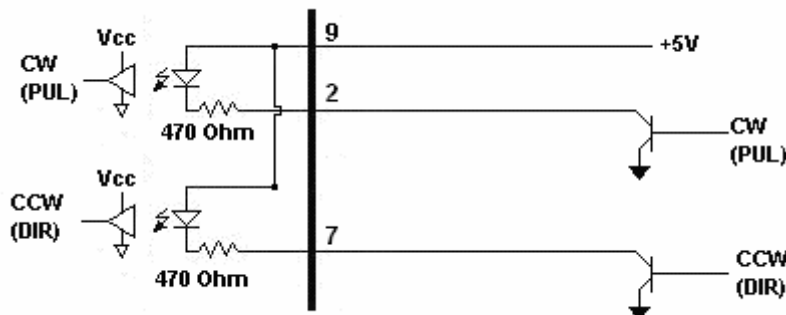

Maximum sink current of the PUL (CW) / DIR (CCW) signals is 40 mA.

Microstep

DMX-A2-DRV comes with Bipolar step motor and has configurable microstep setting range from 2 to 500 microstep.

Current Control

DMX-A2-DRV has configurable current setting from 100mA to 3.0A peak.

Driver current is set to Run Current when the pulse input is detected and remains in run current while the pulse input is detected.

Idle Current is used when the pulse input is idle for the duration set by the Idle Time.

Run Current and the Idle Current should not go over the maximum rated current for each motor size. Use the chart below as a reference on maximum rated current setting.

| Product | Maximum Allowed Driver Current Setting (Amp) |
|-----------------|--|
| DMX-A2-DRV-17-2 | 1.7 |
| DMX-A2-DRV-17-3 | 2.0 |
| DMX-A2-DRV-23-2 | 2.8 |
| DMX-A2-DRV-23-3 | 2.8 |

Enable Input

Enable signal is an opto-isolated input. If there is no connection to enable signal, the driver is enabled by default. Only when the enable signal is connected to the ground of the opto-supply input, the driver is disabled and motor is free.

Example Wiring of Enable Input

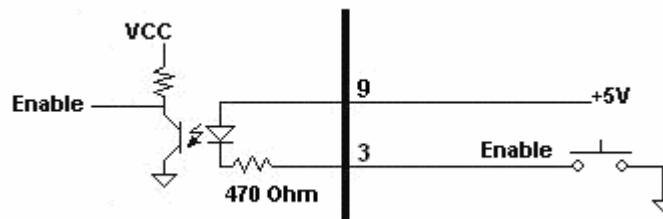

Maximum sink current of the Enable signal is 40 mA.

Over Temperature Alarm Output

DMX-A2-DRV has a temperature sensor to detect over heating of the driver. Temperature sensing is done only when the driver is enabled. When the temperature goes over the over-temperature alarm value 75 degrees Celsius, the Alarm Output is turned on and the driver is turned off until the temperature goes below the 73 degrees Celsius.

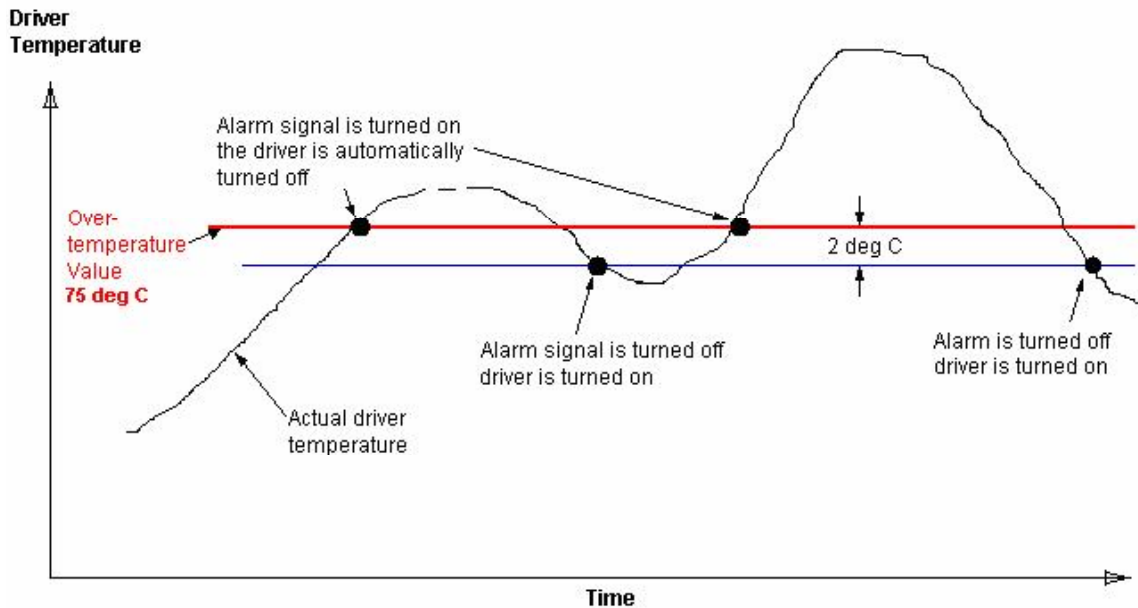

Alarm output is an opto-isolated output with 100 Ohm resistor.

Example Wiring of Alarm Output

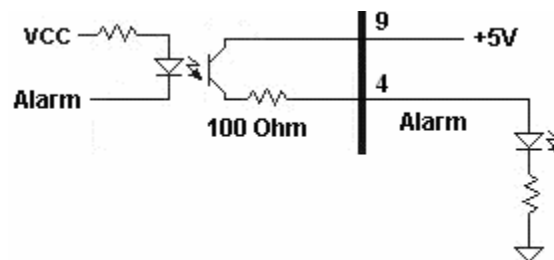

Maximum source current of the alarm output signal is 40 mA.

8. Driver Configuration

Following are DMX-A2-DRV parameters that can be configured:

- 1) Microstep Setting: 2 to 500
- 2) Run Current: 100mA to 3.0A (peak)
- 3) Idle Current: 100mA to 3.0A (peak)
- 4) Idle Time: 100 msec to 10 sec
- 5) Direction Polarity
- 6) One-clock or Two-clock mode

DMX-A2-DRV uses patent-pending Dynamic Configuration Method to read and write the driver parameters using the control signals (Pulse, Dir, Enable, and Alarm) of the driver. Dynamic Configuration eliminates the need for jumpers, switches, resistors, potentiometers and communication port for reading and setting the driver parameters. This results in simple and cost-effective device.

Each DMX-A2-DRV product comes with following default factory settings.

| Product | Micro-Step | Run Current (Amp) | Idle Current (Amp) | Idle Time (msec) | Direction Polarity | Clock Mode |
|-----------------|------------|-------------------|--------------------|------------------|--------------------|------------|
| DMX-A2-DRV-17-2 | 50 | 1.6 | 0.5 | 500 | CCW | One |
| DMX-A2-DRV-17-3 | 50 | 1.6 | 0.5 | 500 | CCW | One |
| DMX-A2-DRV-23-2 | 50 | 2.4 | 1 | 500 | CCW | One |
| DMX-A2-DRV-23-3 | 50 | 2.4 | 1 | 500 | CCW | One |

Important Note: When setting the run and idle current, make sure to keep the current value below the maximum allowed current that each motor can handle. Note the following maximum current that each product can handle.

| Product | Maximum Allowed Driver Current Setting (Amp) |
|-----------------|--|
| DMX-A2-DRV-17-2 | 1.7 |
| DMX-A2-DRV-17-3 | 2.0 |
| DMX-A2-DRV-23-2 | 2.8 |
| DMX-A2-DRV-23-3 | 2.8 |

DMX-A2-DRV driver parameters can be easily configured using the ACE-SXC single axis USB communication motion controller or the DMX-CFG-USB.

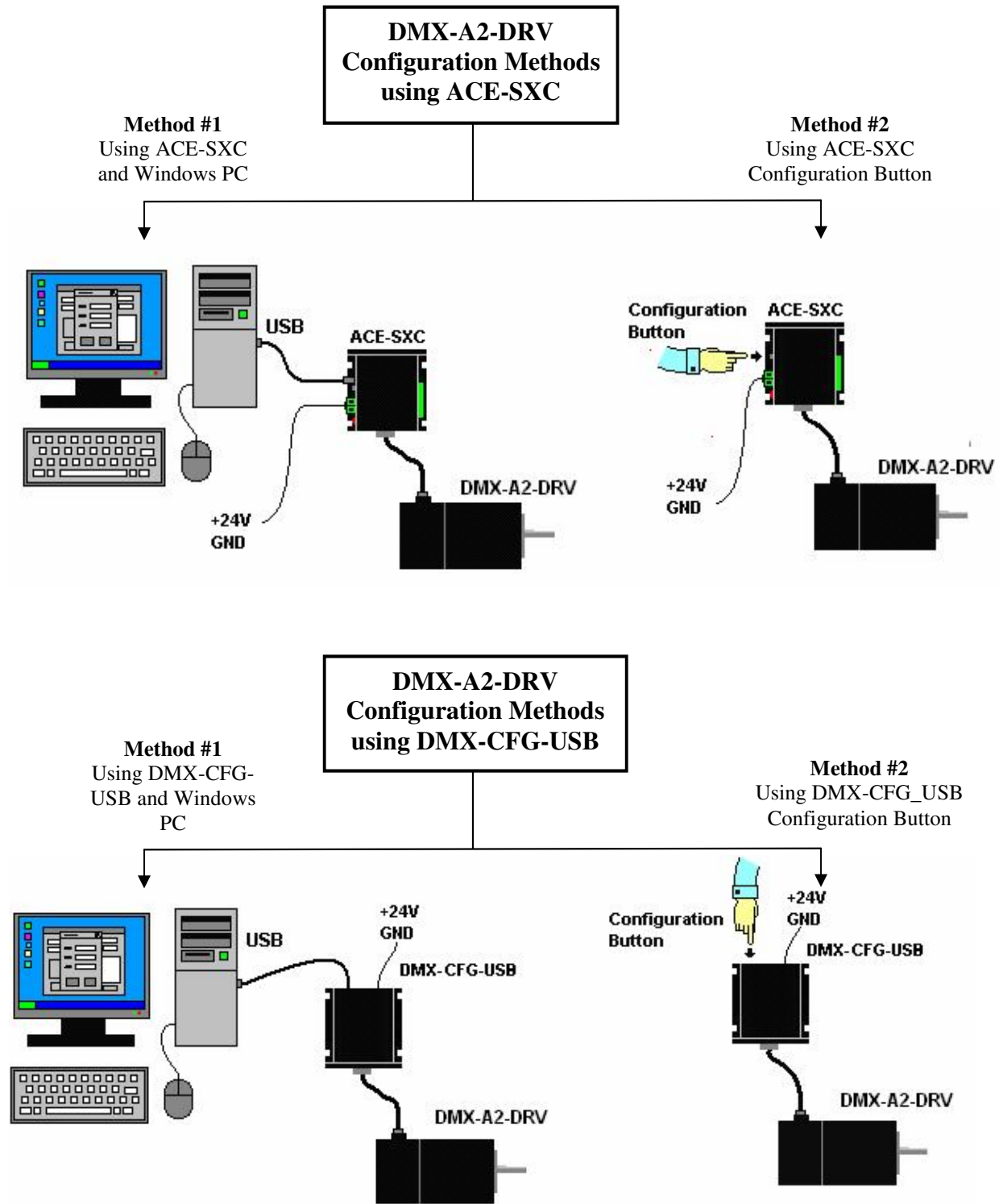

Connecting ACE-SXC/DMX-CFG-USB and DMX-A2-DRV-17/23

Cable Accessory: CBL-DB_9M-DB_9F-L1-G24-V1

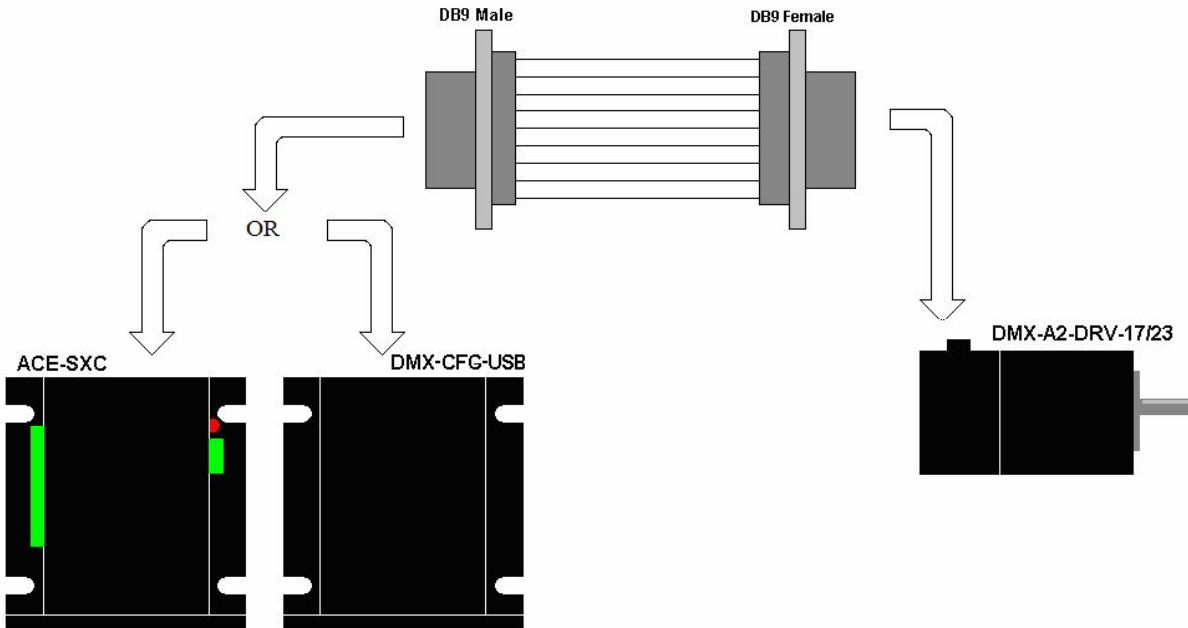

Configuration Method #1 - Using a controller and Windows PC

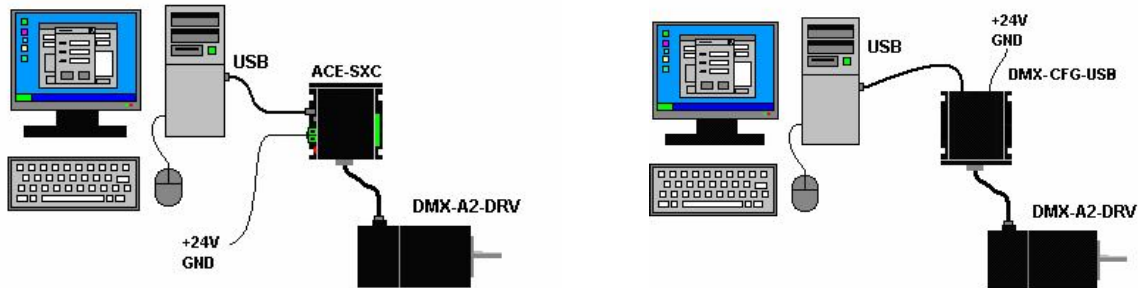

DMX-A2-DRV can be configured quickly and easily using either an ACE-SXC single axis controller or a DMX-CFG-USB and Windows PC. Both ACE-SXC and DMX-CFG-USB requires a USB port to communicate. The proper USB device driver must also be installed before using either controller. For detailed information on ACE-SXC or DMX-CFG-USB controller usage, refer to the ACE-SXC or DMX-CFG-USB manual.

Before using the ACE-SXC or DMX-CFG-USB controller, proper USB driver must be installed first on the Windows PC. If this is the first time using an ACE-SXC or DMX-CFG-USB controller, install the USB device driver first. Do not connect the controller until the proper driver is installed first. Follow the steps to install the USB driver for ACE-SXC or DMX-CFG-USB controller.

USB Device Driver Installation for ACE-SXC/DMX-CFG-USB

- 1) From the Arcus Technology website support section, download the Performax USB driver installation program. Run this USB driver installation program first before connecting the controller to the Windows PC.
- 2) Power the controller using 12-24V power supply. Using a USB cable (mini-B USB cable), connect the controller to the Windows PC. Go through typical USB device installation steps.
- 3) After successful installation, the ACE-SXC or DMX-CFG-USB device should be recognized by the Windows PC and the controller is ready for use.

DMX-A2-DRV Configuration Steps using ACE-SXC and PC

After successful USB device installation of ACE-SXC, download the ACE-SXC Windows program from the Arcus Technology website.

- 1) With ACE-SXC controller powered with 12-24VDC power supply, connected to Windows PC, and properly installed and recognized by Windows PC, the ACE-SXC Windows program will automatically find the controller. If the program is not able to find the controller, it will give an error messages. If there is any error message indicating that the program cannot find the controller, redo the USB device driver installation steps. When program is started, the following screen will show.

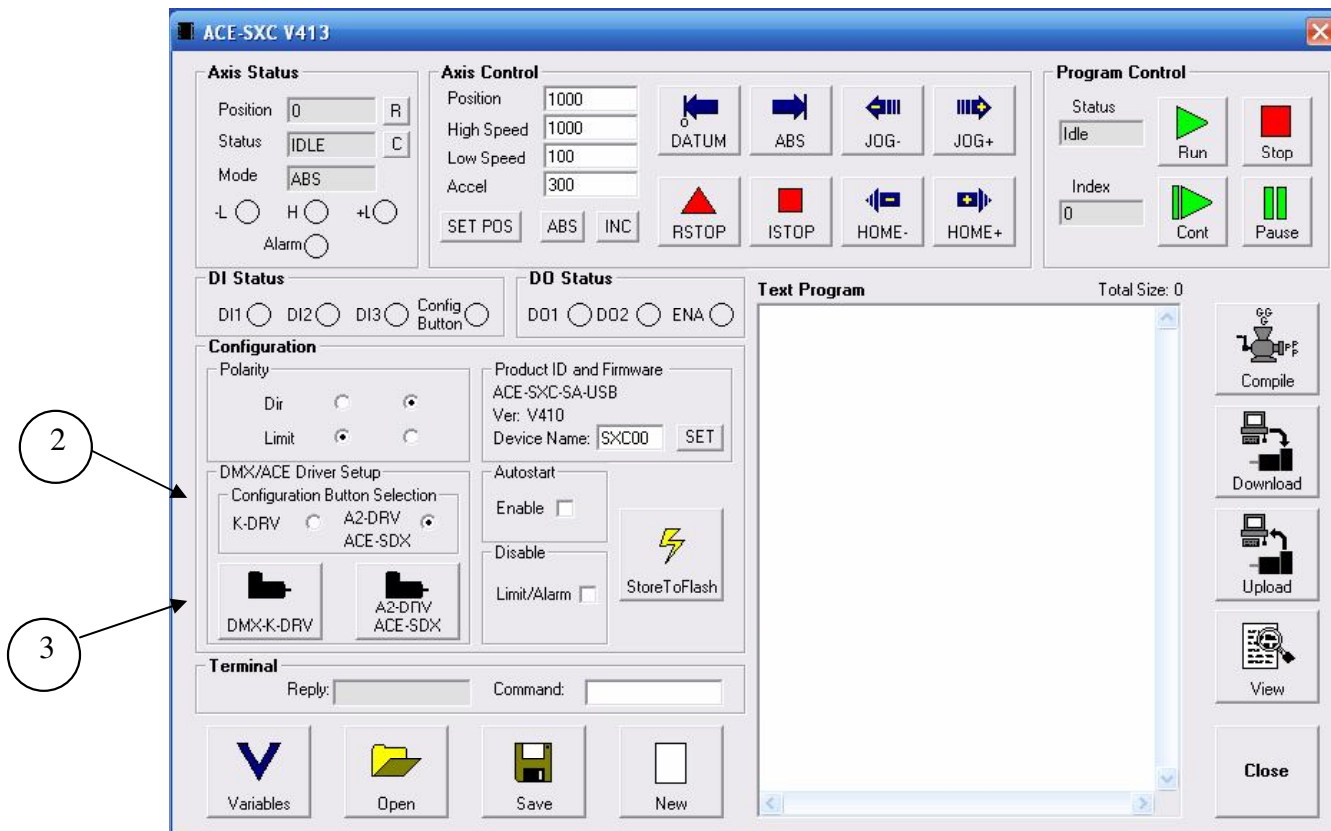

- 2) Select A2-DRV/ACE-SDX option.



- Open DMX-A2-DRV configuration dialog box by clicking on the A2-DRV/ACE-SDX button.

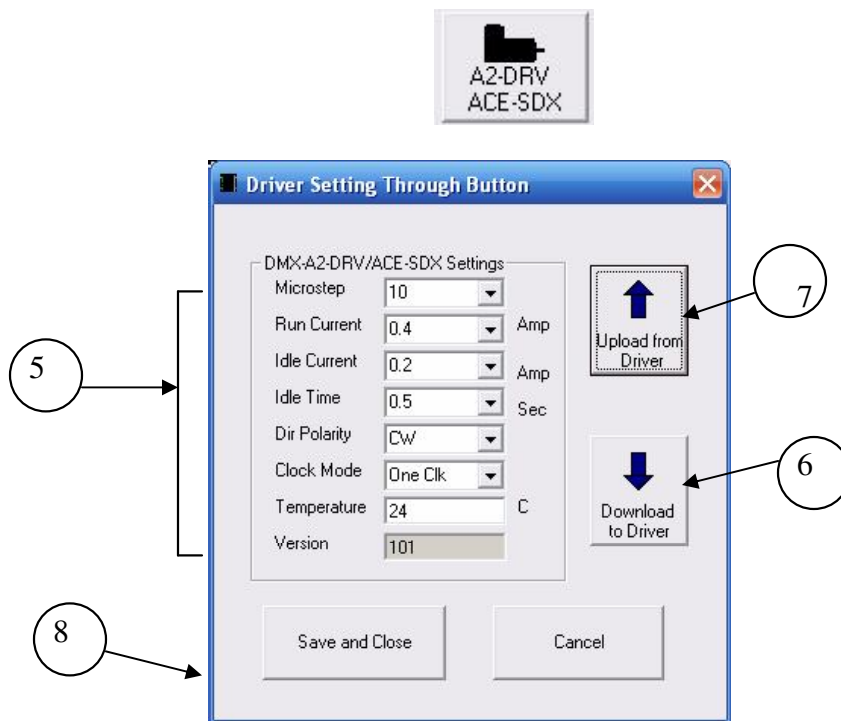

- When A2-DRV/ACE-SDX configuration button is pressed, DMX-A2-DRV configuration dialog box opens as shown above.
- Set the driver settings.

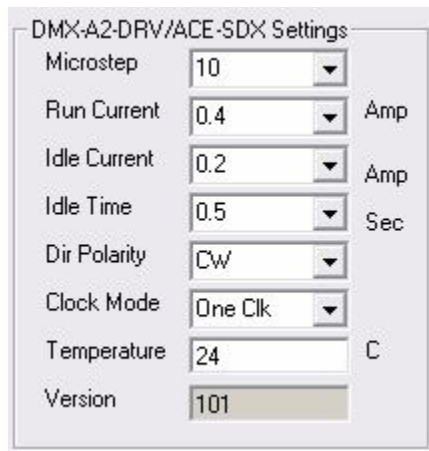

- Click the **Download to Driver** button to download the parameters to the driver.



- 7) Click the **Upload from Driver** button to upload the parameters from the driver.



- 8) **Save and Close** button saves the selected driver settings by storing the values to the ACE-SXC controller.

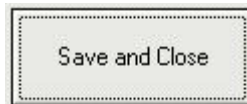

- 9) Once **Save and Close** button is pressed, the parameter values are stored in the RAM (temporary memory) of ACE-SXC controller. The parameter values can be used in the future to download to another DMX-A2-DRV driver. To permanently store the driver parameter values to ACE-SXC controller, select Store to **Flash** button as shown below.

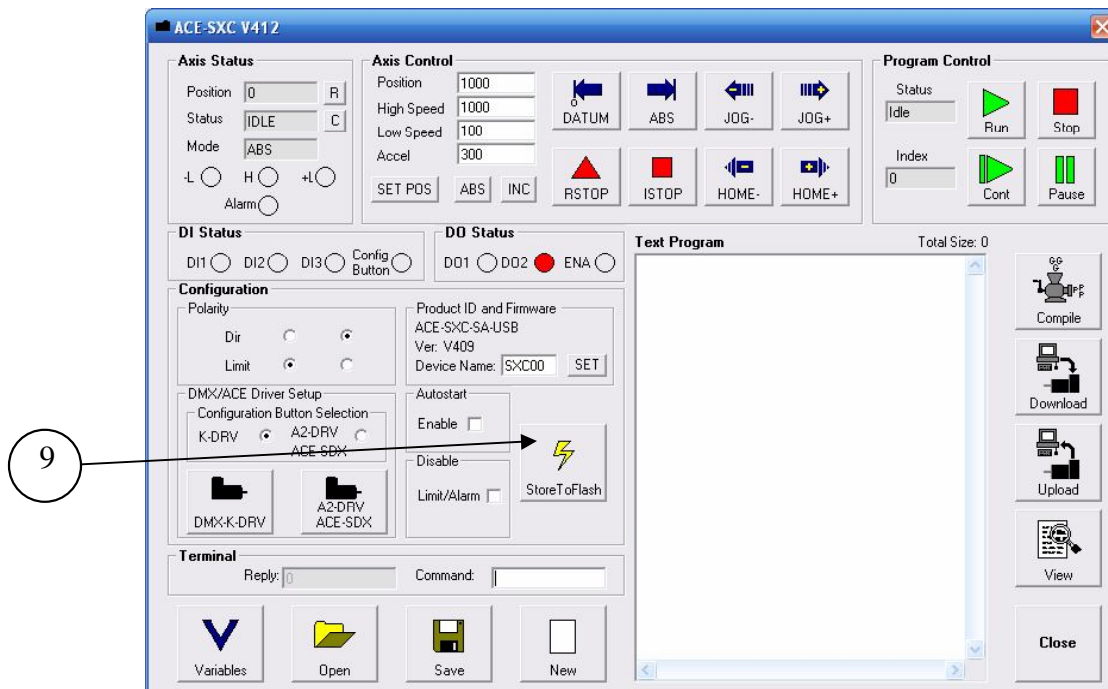

DMX-A2-DRV Configuration Steps using DMX-CFG-USB and PC

After successful USB device installation of DMX-CFG-USB, download the DMX-CFG-USB Windows program from the Arcus Technology website.

- 1) With DMX-CFG-USB controller powered with 12-24VDC power supply, connected to Windows PC, and properly installed and recognized by Windows PC, the DMX-CFG-USB Windows program will automatically find the controller. If the program is not able to find the controller, it will give an error messages. If there is any error message indicating that the program cannot find the controller, redo the USB device driver installation steps. When program is started, the following screen will show.

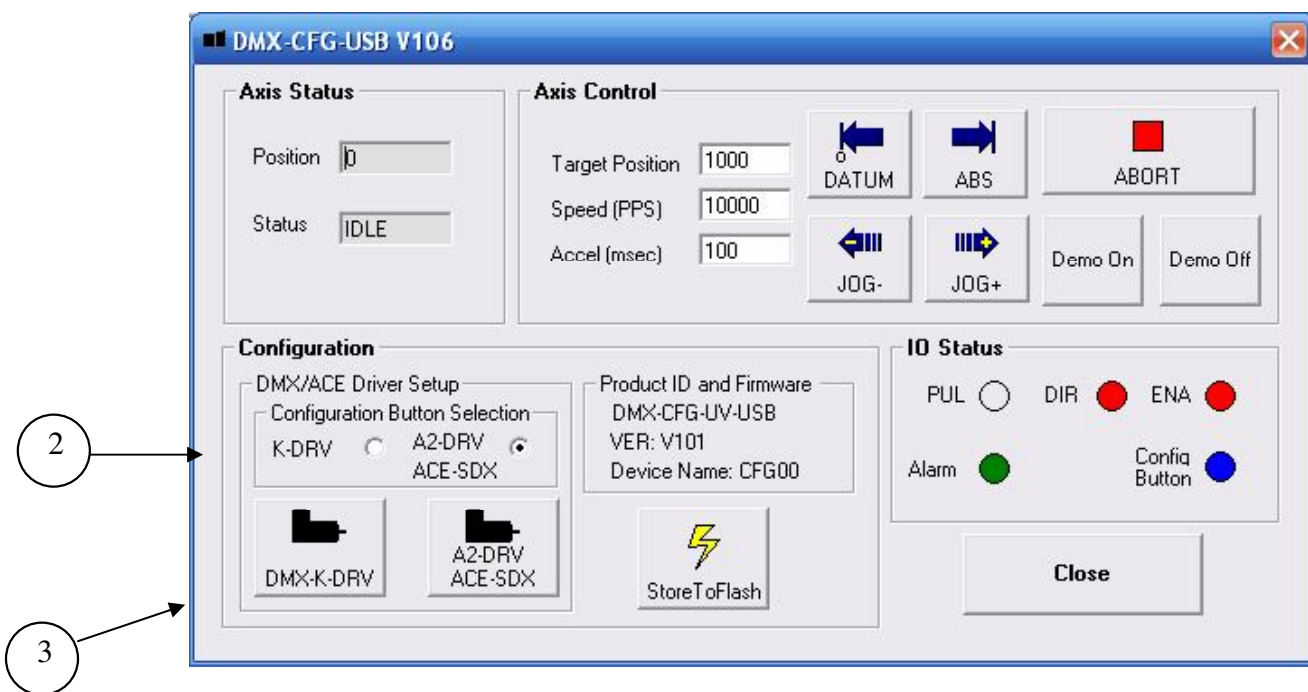

- 2) Select A2-DRV/ACE-SDX option.



- Open DMX-A2-DRV configuration dialog box by clicking on the DMX-A2/ACE-SDX button.

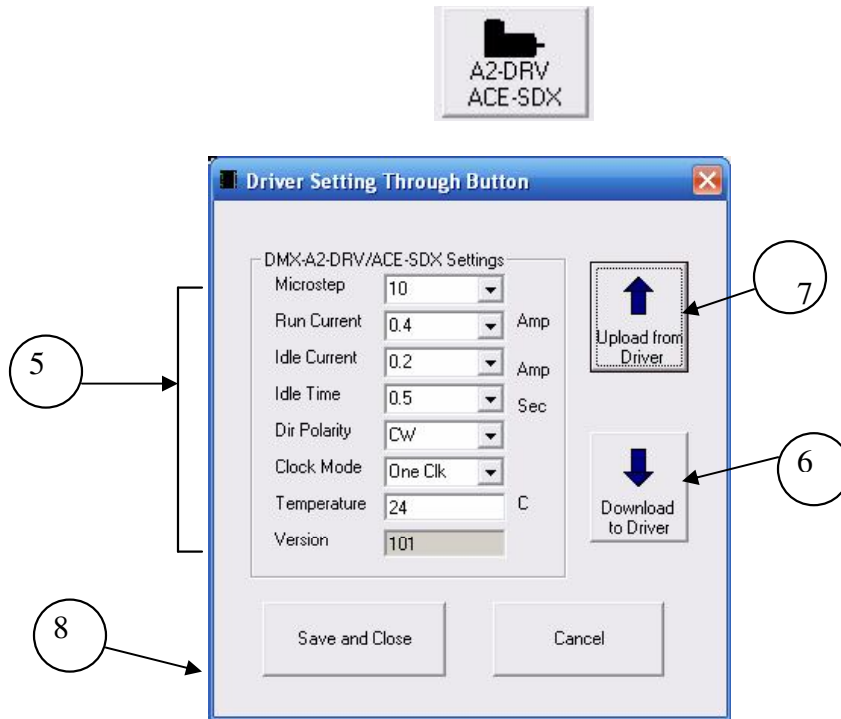

- When A2-DRV/ACE-SDX configuration button is pressed, DMX-A2-DRV configuration dialog box opens as shown above.

- Set the driver settings.

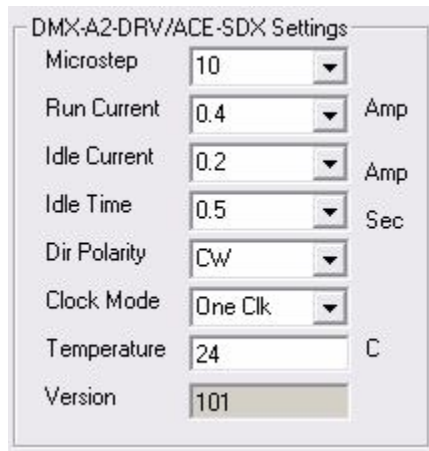

- Click the **Download to Driver** button to download the parameters to the driver.



- 7) Click the **Upload from Driver** button to upload the parameters from the driver.



- 8) **Save and Close** button saves the selected driver settings by storing the values to the DMX-CFG-USB controller.

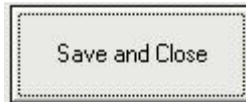

- 9) Once **Save and Close** button is pressed, the parameter values are stored in the RAM (temporary memory) of DMX-CFG-USB controller. The parameter values can be used in the future to download to another DMX-A2-DRV driver. To permanently store the driver parameter values to DMX-CFG-USB controller, select **Store to Flash** button as shown below.

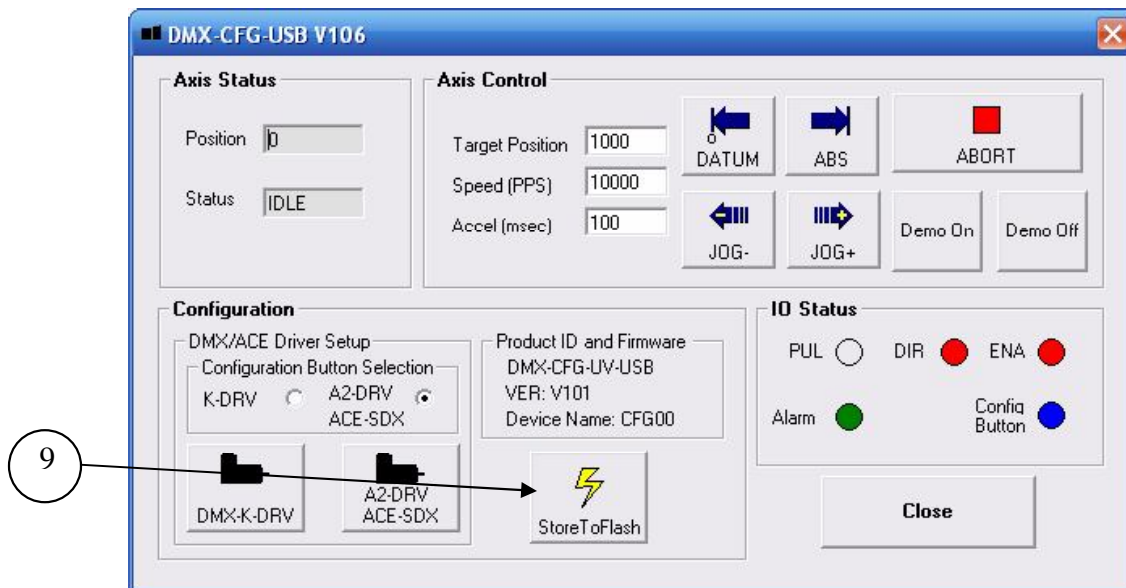

Configuration Method #2 - Using the Configuration Button

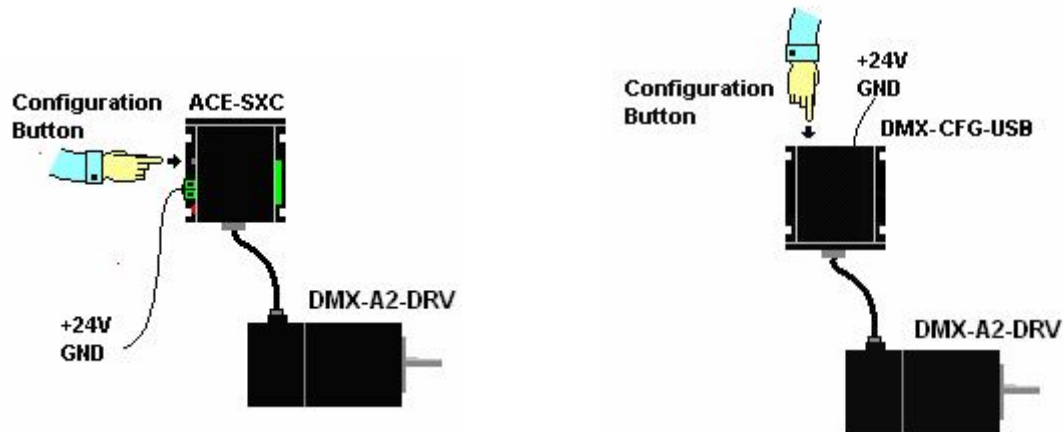

Once the driver parameter values are permanently stored on the flash memory of the ACE-SXC/DMX-CFG-USB controller, driver parameters can be downloaded from ACE-SXC/DMX-CFG-USB to DMX-A2-DRV without the use of Windows PC. For detailed information on using the ACE-SXC or DMX-CFG-USB controller, refer the ACE-SXC or DMX-CFG-USB manual.

- 1) Power the ACE-SXC/DMX-CFG-USB controller using 12-24VDC power supply.
- 2) Connect the control cable between ACE-SXC/DMX-CFG-USB and DMX-A2-DRV. All the control signals (Pulse/Dir/Enable/Alarm) must be connected to work properly.
- 3) Press and hold down the configuration button for 3 seconds. LED on the controller will start blinking quickly.
- 4) While the LED is blinking quickly, release the button and press the button again to start the configuration of the connected driver. While the configuration is done, LED is turned off. Configuration takes about 3 seconds.
- 5) If the configuration is done properly, the LED will blink quickly for 3 seconds. If the configuration is not done properly, LED will blink slowly for 3 seconds.

Contact Information

Arcus Technology, Inc.

3061 Independence Drive, Suite H
Livermore, CA 94551
925-373-8800

www.arcus-technology.com